

Actuated Zone Valves

For zoning large effluent distribution networks

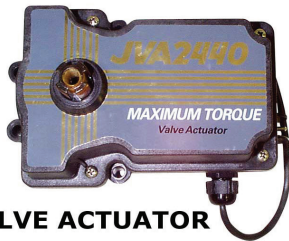

ZONE VALVES



VALVE ACTUATOR

Clarus Environmental's Actuated Zone Valves provide an economical method of zoning large effluent distribution networks. The valves are easily automated with the addition of the motor actuator. The zone valve body is designed to allow maximum water flow while maintaining strength. The zone valves are highly reliable, easy to install, and easy to use. The three port valves can be used to alternate between fields on any pumped system while the two port valve operate as a simple shutoff valve. The 24 volt valve actuator can stop or start diverters in any position. Zoning may also allow for a reduction in the pump size.

Features

- Valve never needs lubrication
- Valve may be operated manually
- Actuator utilizes 24 volt AC power
- Actuator movement is completely customizable
- No solenoids to burn out

Actuated Zone Valves	
Part Number	Description
170-0048	3-Port valve asm, 2" ID x 2.5 OD
170-0049	2-Port valve asm, 2" ID x 2.5 OD
170-0050	Actuator, valve 24V
170-0149	3-Port valve asm, 1.5" ID x 2" OD
170-0150	2-Port valve asm, 1.5" ID x 2" OD

Trusted. Tested. Tough.®

3649 Cane Run Road • Louisville, KY 40211-1961 • (502) 778-2731 • FAX: (502) 774-3624
clarusenvironmental.com

C4.00.061
 CL0087
 0319
 Supersedes
 1111

Zone Valve - Installation and Mounting

Materials Used:

Valve Screws: Stainless Steel

Valve Knob: ABS Plastic

Valve Handle: ABS Plastic

Valve Cover: CPVC Plastic

Large O-Ring (151):

Teflon-impregnated plastic

Small O-Ring (116):

Teflon-impregnated plastic

Valve Housing (Main Valve Body):

CPVC plastic

Valve Diverter: Glass-filled Noryl

Valve Diverter Seal Valve:

NeverLube™ Material

Technical Specifications:

Working Pressure: 50 psi.

Burst Pressure: 200 psi.

Positive Seal Back Pressure: 15 psi.

Chlorine Resistant

Acid Resistant

Ozone Resistant

THREE PORT VALVE

Standard Plumbing position is with the middle (Port B) as the incoming or common port to the valve (diagram 1).

Standard Mounting position is with the main body of the actuator over Port B as in diagram (2).

If it is necessary to plumb the valve in other than the standard position, please refer to the full installation manual for detailed instructions on adjusting the internal cams.

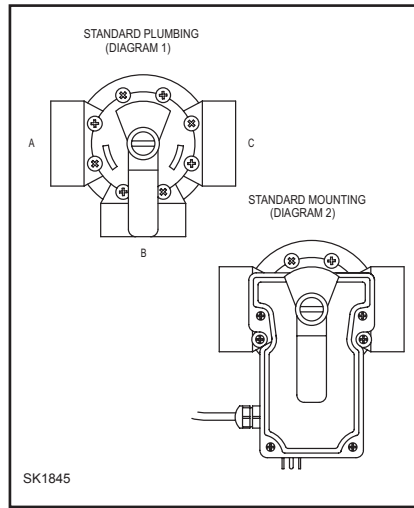

TWO PORT VALVE

If a two port valve is used, it will be necessary to change the cam settings inside the actuator. Please refer to the full installation manual for detailed instructions on adjusting the internal cams.

ACTUATOR MOUNTING ON VALVE

- Unscrew (counter-clockwise) the locking knob and remove it and the valve handle.
- Remove four Phillips-head screws from the valve. Which screws you remove depends on how you mount the actuator.
- Turn the actuator over so you can see into the brown actuator shaft. There are four "teeth". Note the one which is smaller than the others. Align this smallest tooth with the smallest slot on the valve diverter.
- Rotate the actuator while keeping the two shafts engaged until the holes on the actuator legs align with the holes left when you removed the screws in step B.
- Use the long screws (packaged with the actuator) to secure it in place.
- Put the valve handle on the actuator shaft. Screw down and tighten the locking knob (finger tight only).

Valve Actuator P/N 170-0050

Technical Specifications:

Voltage: 24 V.A.C.

Amperage: 0.9 AMPS

Cycles: 60 Hz

Wire: 3 Conductor

Black -- Common

**Red
White] - Switch Legs**

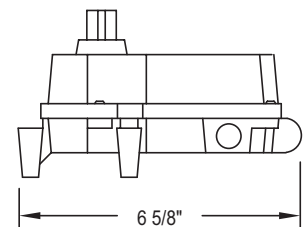
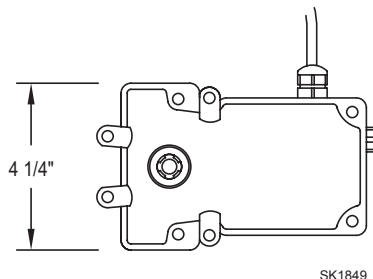
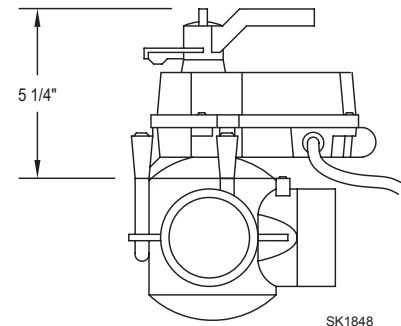
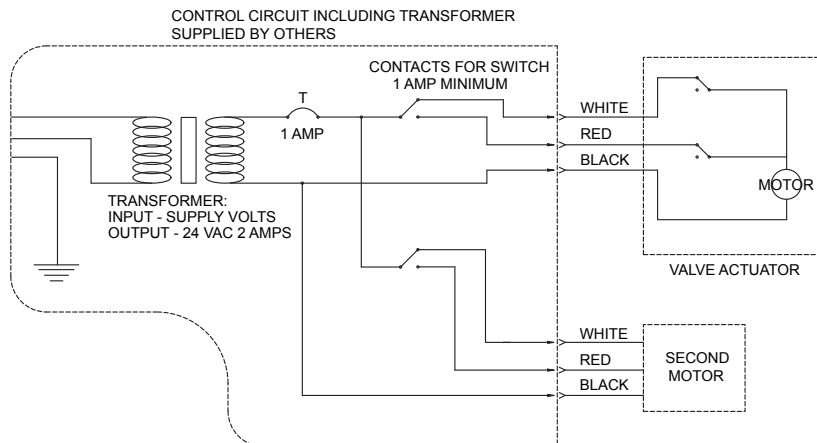

ALL ZOELLER ON-SITE WASTEWATER PRODUCTS MUST BE INSTALLED IN ACCORDANCE WITH LOCAL AND/OR STATE PLUMBING AND/OR HEALTH DEPARTMENT CODES.

© Copyright 2019 Zoeller® Co. All rights reserved.

502-778-2731 | 800-928-7867 | 3649 Cane Run Road | Louisville, KY 40211-1961 | clarusenvironmental.com